

Go to www.vtechcanada.com for the latest VTech product news.

SN7021

Cordless Audio Doorbell
for use with
VTech SN5127/SN5147
telephone system



vtech®

User's manual (Canada version)

Congratulations

on purchasing your new VTech product. Before using this product, please read important safety instructions.

This user's manual has instructions on how to set up and register your new Audio doorbell. For instructions on using the Audio doorbell, see the Quick start guide or the online Complete user's manual of your telephone system.

For support, shopping, and everything new at VTech, visit our website at www.vtechcanada.com.

What's in the box

Your product package contains the following items. Save your sales receipt and original packaging in the event warranty service is necessary.

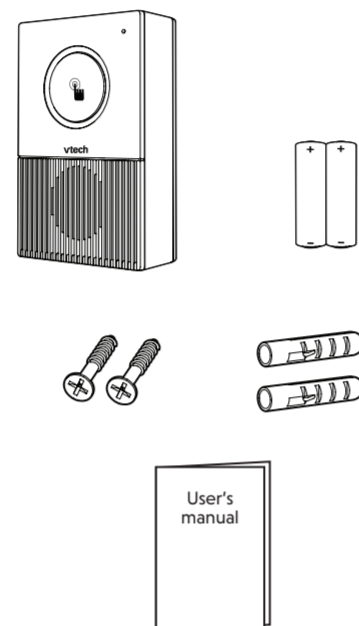

Overview

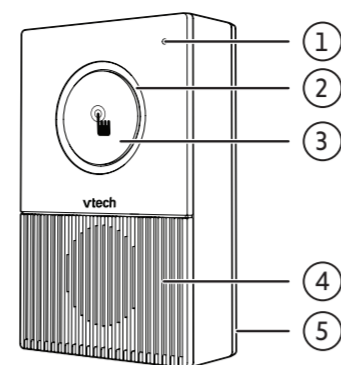

1 – Microphone

2 – LED light

- Flashes when the doorbell is chimed or in pairing mode.

3 – Chime button

- Press to send a chime tone and notification to the cordless handset and telephone base.

4 – Speaker

5 – Wall mount cover

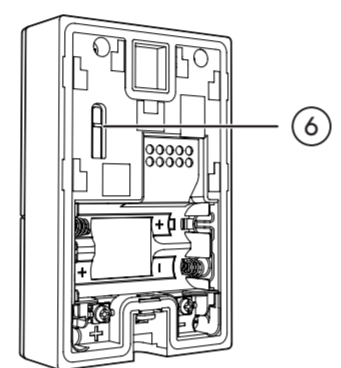

6 – Pair button

- Press and hold to enter pairing mode.

Install the battery

Install doorbell batteries

NOTES

- Use only the batteries provided or equivalent.
- If the doorbell will not be used for a long time, disconnect and remove the batteries to prevent possible leakage.

- Use a slot type screwdriver to loosen the screw at the bottom of the Audio doorbell.

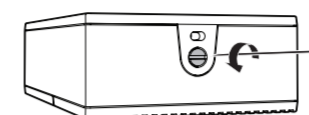

- Pull the wall mount cover of the Audio doorbell downward, and then detach it from the doorbell.

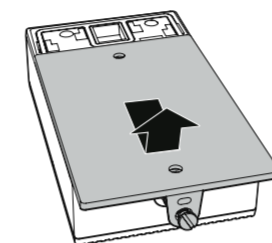

- Insert the supplied batteries into the battery compartment, and match the polarity markings (+ and -) inside it.

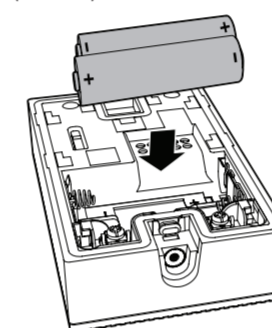

NOTE

- Register the Audio doorbell to your telephone base before closing the wall mount cover and tightening the screw at the bottom of the Audio doorbell. Refer to the **Add and register an Audio doorbell** section in this user's manual.

Before use

Add and register an Audio doorbell

Register each new **SN7021** Audio doorbell to your **SN5127/SN5147** telephone base before use. Your telephone system supports a maximum of two Audio doorbells.

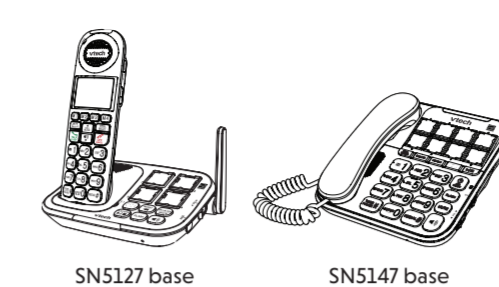

NOTE

- Install the supplied batteries before registering the Audio doorbell to the telephone base.

To register an Audio doorbell to the SN5127 telephone base:

- When the telephone is not in use, **press and hold PAGE** at the telephone base for about five seconds until the visual ringer indicator light turns on. Release **PAGE**.

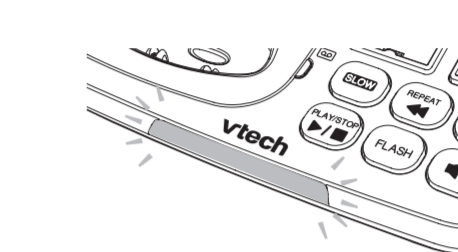
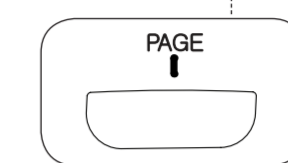
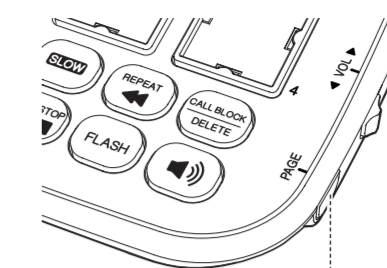

- Press and hold the pair button on the back of the Audio doorbell until the LED light at the front flashes, then release it.

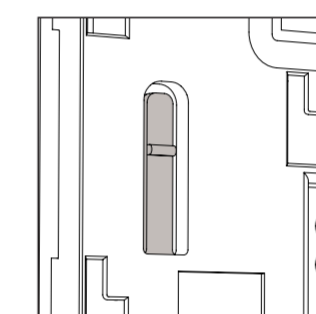

It takes up to 60 seconds to complete the registration. When the registration is successful, the LED light on the front of the Audio doorbell turns to steady on, and the telephone base beeps and its visual ringer indicator light turns off.

If registration fails, start again from Step 1 above.

NOTE

- You cannot register an Audio doorbell if any other system device is in use.

To register an Audio doorbell to the SN5147 telephone base:

- When the telephone is not in use, **press and hold PAGE/INTERCOM** at the telephone base for about five seconds until the visual ringer indicator light turns on. Release **PAGE/INTERCOM**.

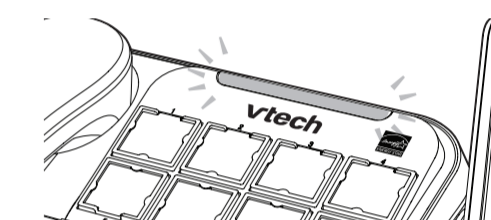
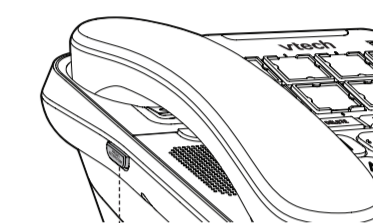

- Press and hold the pair button on the back of the Audio doorbell until the LED light at the front flashes, then release it.

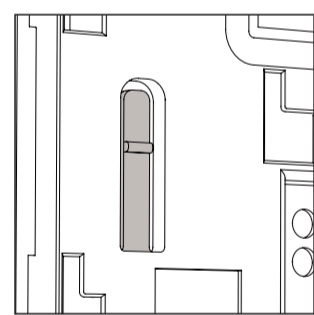

It takes up to 60 seconds to complete the registration. When the registration is successful, the LED light on the front of the Audio doorbell turns to steady on, and the telephone base beeps and its visual ringer indicator light turns off. If registration fails, start again from Step 1 above.

NOTES

- You cannot register an Audio doorbell if any other system device is in use.

Close the wall mount cover

After you have registered your Audio doorbell to the telephone base:

- Close the wall mount cover and push it upward until it is securely in place.

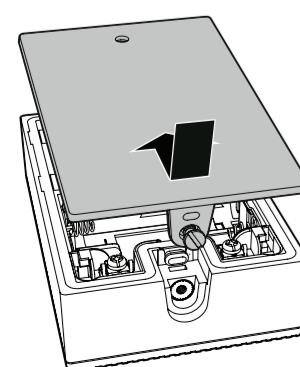

- Tighten the screw at the bottom of the wall mount cover.

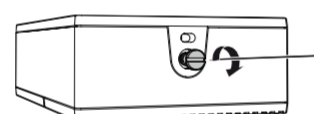

NOTE

- If you choose to mount the Audio doorbell on a wall, refer to **Test the signal strength** and **Mount the Audio doorbell** sections in this user's manual before closing the wall mount cover.

Operating range

The operating range of the Audio doorbell is up to 1,000 feet outdoors or 150 feet indoors. The actual operating range may vary depending on the environmental conditions and other interferences such as walls, doors and other obstructions.

Test the signal strength

You can mount the Audio doorbell on a wall.

Before you mount the Audio doorbell, follow the instructions below to check the signal strength between the Audio doorbell and the telephone base. Make sure you mount the device in a location where the signal strength is good.

Test device signal strength with your SN5127/SN5147 telephone

- Press **MENU** on the cordless handset when the telephone is not in use.
- Press **▼** or **▲** to scroll to **Set device**, and then press **SELECT**.
- Press **SELECT** again to select **Check signal**.
- Scroll to select **DOORBELL X** (X represents the device number assigned to the doorbell) and then press **SELECT**.
- While the handset screen displays **Awaiting signal**, press **🔊** on the front of the Audio doorbell.
- When the handset screen displays **Good signal**, press **SELECT**. The testing is complete.
 - If the handset screen displays **No signal**, press **SELECT**. Make sure the doorbell is powered on with the batteries, and then repeat from step 1 to test again.
 - If the handset screen displays **Weak signal**, press **SELECT**. Then, move the Audio doorbell closer to the base, and then adjust the Audio doorbell's location to improve the signal. Repeat from step 1 to test again.

For detailed operations, read the **Audio doorbell** section in the Quick start guide or the online Complete user's manual of your telephone system.

Mount the Audio doorbell

NOTE

- The types of screws and anchors you need depend on the composition of the wall. You may need to purchase the screws and anchors separately to mount your doorbell.

Install doorbell wall mount cover

Attach the wall mount cover to the wall:

- Use a pencil to mark two holes on the desired location. Then remove the wall mount cover and drill two holes in the wall. Check for reception strength before drilling the holes.

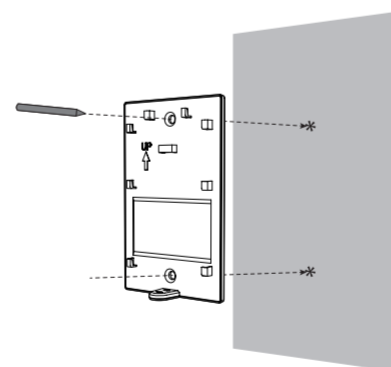

- If you drill the holes into a stud, go to step 3.

-OR-

If you drill the holes into an object other than a stud, insert the wall anchors into the holes and tap gently on the ends with a hammer until the wall anchors are flush with the wall.



- Align the holes on the wall mount cover with the holes on the wall (or stud). Tighten the screws into the holes to secure the wall mount cover onto the wall.

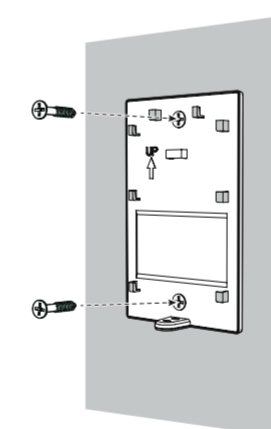

Install doorbell

Attach the doorbell to the wall mount cover on the wall:

- Align the doorbell with the slots on the wall mount cover.

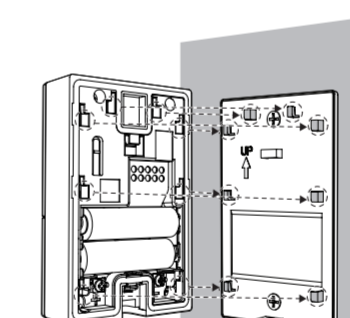

- Attach the doorbell to the wall mount cover, and then push the doorbell downward gently until it is sealed tightly.

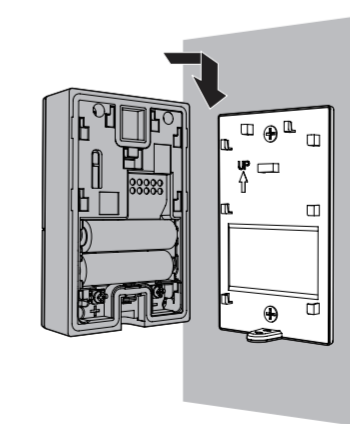

- Tighten the screw into the threaded socket at the bottom to secure.

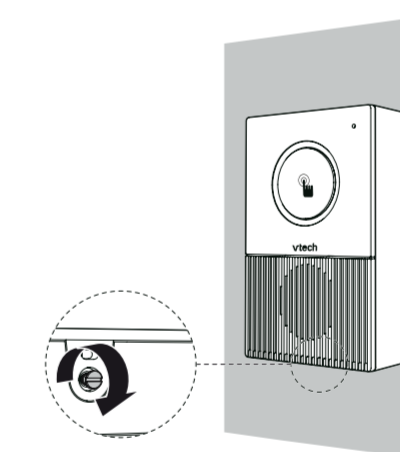

Replace an Audio doorbell

You can deregister an Audio doorbell, or deregister all devices when you want to:

- Replace an old Audio doorbell with a new one;
- Reassign the designated number of your Audio doorbell; or
- Register your Audio doorbell to another telephone system.

To deregister an Audio doorbell or deregister all devices:

Using a cordless handset when it is not in use:

- Press **MENU** on the handset, and then press ***33734#**.
 - When the **DEREGISTER** menu options display:
 - Press **SELECT** to select **All sensors**. All devices will be deregistered.
- OR-
- Scroll to **Single sensor** and then press **SELECT**. Then, select the desired device and then press **SELECT** to deregister that device.

General product care

To keep this product working well and looking good, follow these guidelines:

- Avoid putting it near heating appliances and devices that generate electrical noise (for example, motors or fluorescent lamps).
- DO NOT expose it to direct sunlight or moisture.
- Avoid dropping the product or treating it roughly.
- Clean with a soft cloth.
- DO NOT immerse the Audio doorbell in water and do not clean them under the tap.
- DO NOT use cleaning spray or liquid cleaners.
- Make sure the Audio doorbell is dry before you connect it to the mains again.

Storage

When you are not going to use the Audio doorbell for some time, remove the batteries from the Audio doorbell. Store the Audio doorbell in a cool and dry place.

Frequently asked questions

Below is the question most frequently asked about the Audio doorbell. If you cannot find the answer to your question in the below table, visit our website at www.vtechcanada.com or call **1 (800) 267-7377** for customer service.

The Audio doorbell doesn't work with the telephone system equipment.	Make sure the AA batteries ares installed.
	The Audio doorbell may be deregistered from your telephone system. Refer to Add and register an Audio doorbell and register the Audio doorbell back.
	The Audio doorbell may be out of range. Place or install the doorbell closer to the telephone system.
	If the above suggestions do not work, deregister the doorbell and register it to the telephone base again.

Important safety instructions

When using your Audio doorbell, basic safety precautions should always be followed to reduce the risk of fire, electric shock and injury, including the following:

- Read and understand all instructions.
- Follow all warnings and instructions marked on the product.
- Unplug this product from the wall outlet before cleaning. Do not use liquid or aerosol cleaners. Use a dry non-abrasive cloth for cleaning.
- Do not use this product near water such as near a bath tub, wash bowl, kitchen sink, laundry tub or a swimming pool, or in a wet basement or shower.
- Do not place this product on an unstable table, shelf, stand or other unstable surfaces.
- Avoid placing the device in places with extreme temperature, direct sunlight, or other electrical devices. Protect your Audio Doorbell from moisture, dust, corrosive liquids and fumes.
- This product should not be placed in any area where proper ventilation is not provided. Slots and openings in the back or bottom of this product are provided for ventilation. To protect them from overheating, these openings must not be blocked by placing the product on a soft surface such as a bed, sofa or rug. This product should never be placed near or over a radiator or heat register.
- This product should be operated only from the type of power source indicated on the marking label. If you are not sure of the type of power supply in your home, consult your dealer or local power company.
- Do not allow anything to rest on the power cord. Do not install this product where the cord may be walked on.
- Never push objects of any kind into this product through the slots because they may touch dangerous voltage points or create a short circuit. Never spill liquid of any kind on the product.
- To reduce the risk of electric shock, do not disassemble this product, but take it to an authorized service facility. Opening or

removing parts of the Audio Doorbell other than specified access doors may expose you to dangerous voltages or other risks. Incorrect reassembling can cause electric shock when the product is subsequently used.

- Do not overload wall outlets and extension cords.
- Unplug this product from the wall outlet and refer servicing to an authorized service facility under the following conditions:
 - When the power supply cord or plug is damaged or frayed.
 - If liquid has been spilled onto the product.
 - If the product has been exposed to rain or water.
 - If the product does not operate normally by following the operating instructions. Adjust only those controls that are covered by the operation instructions. Improper adjustment of other controls may result in damage and often requires extensive work by an authorized technician to restore the product to normal operation.
 - If the product has been dropped or damaged.
 - If the product exhibits a distinct change in performance.
- Avoid using the product during an electrical storm. There is a remote risk of electric shock from lightning.
- Periodically examine all components for damage.
- CAUTION:** Use only the batteries indicated in this manual. There may be a risk of explosion if a wrong type of battery is used for the Audio Doorbell. Do not dispose of batteries in a fire. They may explode.

SAVE THESE INSTRUCTIONS

Battery

- CAUTION: To prevent risk of fire or battery explosion, replace with the correct battery type.
- Dispose of used batteries according to the instructions.

- Batteries should not be exposed to excessive heat such as bright sunshine or fire.
- Do not dispose of the batteries in a fire. Check with local waste management codes for special disposal instructions.
- Do not open or mutilate the batteries. Released electrolyte is corrosive and may cause burns or injury to the eyes or skin. The electrolyte may be toxic if swallowed.
- Exercise care in handling batteries in order not to create a short circuit with conductive materials.

Precautions for users of implanted cardiac pacemakers

Cardiac pacemakers (applies only to digital cordless devices):

Wireless Technology Research, LLC (WTR), an independent research entity, led a multidisciplinary evaluation of the interference between portable wireless devices and implanted cardiac pacemakers. Supported by the U.S. Food and Drug Administration, WTR recommends to physicians that:

Pacemaker patients

- Should keep wireless devices at least six inches from the pacemaker.
- Should NOT place wireless devices directly over the pacemaker, such as in a breast pocket, when it is turned ON.

WTR’s evaluation did not identify any risk to bystanders with pacemakers from other persons using wireless devices.

Electromagnetic fields (EMF)

This VTech product complies with all standards regarding electromagnetic fields (EMF). If handled properly and according to the instructions in this user’s manual, the product is safe to be used based on scientific evidence available today.

FCC and IC regulations

FCC Part 15

NOTE: This equipment has been tested and found to comply with the requirements for a Class B digital device under Part 15 of the Federal Communications Commission (FCC) rules. These requirements are intended to provide reasonable protection against harmful interference in a residential installation. This equipment generates, uses and can radiate radio frequency energy and, if not installed and used in accordance with the instructions, may cause harmful interference to radio communications. However, there is no guarantee that interference will not occur in a particular installation. If this equipment does cause harmful interference to radio or television reception, which can be determined by turning the equipment off and on, the user is encouraged to try to correct the interference by one or more of the following measures:

- Reorient or relocate the receiving antenna.
- Increase the separation between the equipment and receiver.
- Connect the equipment into an outlet on a circuit different from that to which the receiver is connected.
- Consult the dealer or an experienced radio/ TV technician for help.

WARNING: Changes or modifications to this equipment not expressly approved by the party responsible for compliance could void the user’s authority to operate the equipment.

This device complies with Part 15 of the FCC rules. Operation is subject to the following two conditions: (1) this device may not cause harmful interference, and (2) this device must accept any interference received, including interference that may cause undesired operation.

To ensure safety of users, the FCC has established criteria for the amount of radio frequency energy that can be safely absorbed by a user or bystander according to the intended usage of the product. This product has been tested and found to comply with the FCC criteria. The Audio Doorbell shall be installed and used such that parts of all persons’ body are maintained at a distance of approximately 20 cm (8 inches) or more.

This Class B digital apparatus complies with Canadian requirement:
CAN ICES-3 (B)/NMB-3(B)

Industry Canada

This device complies with Industry Canada licence-exempt RSS standard(s).

Operation is subject to the following two conditions: (1) this device may not cause harmful interference, and (2) this device must accept any interference received, including interference that may cause undesired operation.

The term “IC.” before the certification/ registration number only signifies that the Industry Canada technical specifications were met.

This product meets the applicable Innovation, Science and Economic Development Canada technical specifications.

RF radiation exposure statement

The Audio Doorbell complies with FCC RF radiation exposure limits set forth for an uncontrolled environment. The Audio Doorbell should be installed and operated with a minimum distance of 20 cm (8 inches) between the Audio Doorbell and all persons’ body. Use of other accessories may not ensure compliance with FCC RF exposure guidelines. This transmitter must not be co-located or operating in conjunction with any other antenna or transmitter. This equipment complies also with Industry Canada RSS-102 with respect to Canada’s Health Code 6 for Exposure of Humans to RF Fields.

Limited warranty

What does this limited warranty cover?

The manufacturer of this VTech Product warrants to the holder of a valid proof of purchase (“Consumer” or “you”) that the Product and all accessories provided in the sales package (“Product”) are free from defects in material and workmanship, pursuant to the following terms and conditions, when installed and used normally and in accordance with the Product operating instructions. This limited warranty extends only to the Consumer for Products purchased and used in the United States of America and Canada.

What will VTech do if the Product is not free from defects in materials and workmanship during the limited warranty period (“Materially Defective Product”)?

During the limited warranty period, VTech’s authorized service representative will repair or replace at VTech’s option, without charge, a Materially Defective Product. If we repair the Product, we may use new or refurbished replacement parts. If we choose to replace the Product, we may replace it with a new or refurbished Product of the same or similar design. We will retain defective parts, modules, or equipment. Repair or replacement of the Product, at VTech’s option, is your exclusive remedy. VTech will return the repaired or replacement Products to you in working condition. You should expect the repair or replacement to take approximately 30 days.

How long is the limited warranty period?

The limited warranty period for the Product extends for ONE (1) YEAR from the date of purchase. If VTech repairs or replaces a Materially Defective Product under the terms of this limited warranty, this limited warranty also applies to the repaired or replacement Product for a period of either (a) 90 days from the date the repaired or replacement Product is shipped to you or (b) the time remaining on the original one-year warranty; whichever is longer.

What is not covered by this limited warranty?

This limited warranty does not cover:

- Product that has been subjected to misuse, accident, shipping or other physical damage, improper installation, abnormal operation or handling, neglect, inundation, fire, water or other liquid intrusion; or
- Product that has been damaged due to repair, alteration or modification by anyone other than an authorized service representative of VTech; or
- Product to the extent that the problem experienced is caused by signal conditions, network reliability, or cable or antenna systems; or
- Product to the extent that the problem is caused by use with non-VTech accessories; or
- Product whose warranty/quality stickers, product serial number plates or electronic serial numbers have been removed, altered or rendered illegible; or
- Product purchased, used, serviced, or shipped for repair from outside the United States of America or Canada, or used for commercial or institutional purposes (including but not limited to Products used for rental purposes); or
- Product returned without a valid proof of purchase (see item 2 on the next page); or
- Charges for installation or set up, adjustment of customer controls, and installation or repair of systems outside the unit.

How do you get warranty service?

To obtain warranty service, please visit our website at www.vtechcanada.com or call 1 (800) 267-7377.

NOTE: Before calling for service, please review the user’s manual - a check of the Product’s controls and features may save you a service call. Except as provided by applicable law, you

assume the risk of loss or damage during transit and transportation and are responsible for delivery or handling charges incurred in the transport of the Product(s) to the service location. VTech will return repaired or replaced Product under this limited warranty. Transportation, delivery or handling charges are prepaid. VTech assumes no risk for damage or loss of the Product in transit. If the Product failure is not covered by this limited warranty, or proof of purchase does not meet the terms of this limited warranty, VTech will notify you and will request that you authorize the cost of repair prior to any further repair activity. You must pay for the cost of repair and return shipping costs for the repair of Products that are not covered by this limited warranty.

What must you return with the Product to get warranty service?

- Return the entire original package and contents including the Product to the VTech service location along with a description of the malfunction or difficulty; and
- Include a “valid proof of purchase” (sales receipt) identifying the Product purchased (Product model) and the date of purchase or receipt; and
- Provide your name, complete and correct mailing address, and telephone number.

Other limitations

This warranty is the complete and exclusive agreement between you and VTech. It supersedes all other written or oral communications related to this Product. VTech provides no other warranties for this Product. The warranty exclusively describes all of VTech’s responsibilities regarding the Product. There are no other express warranties. No one is authorized to make modifications to this limited warranty and you should not rely on any such modification.

State/Provincial Law Rights: This warranty gives you specific legal rights, and you may also have other rights, which vary from state to state or province to province.

Limitations: Implied warranties, including those of fitness for a particular purpose and merchantability (an unwritten warranty that

the Product is fit for ordinary use) are limited to one year from the date of purchase. Some states/provinces do not allow limitations on how long an implied warranty lasts, so the above limitation may not apply to you. In no event shall VTech be liable for any indirect, special, incidental, consequential, or similar damages (including, but not limited to lost profits or revenue, inability to use the Product or other associated equipment, the cost of substitute equipment, and claims by third parties) resulting from the use of this Product. Some states/provinces do not allow the exclusion or limitation of incidental or consequential damages, so the above limitation or exclusion may not apply to you.

Please retain your original sales receipt as proof of purchase.

Technical specifications

Frequency control	Crystal controlled PLL synthesizer
Transmit frequency	1921.536-1928.448 MHz
Channels	5
Nominal effective range	Maximum power allowed by FCC and IC. Actual operating range may vary according to environmental conditions at the time of use.
Power requirements	Battery: 2 x AA Alkaline battery, 1.5V DC 2800mAh

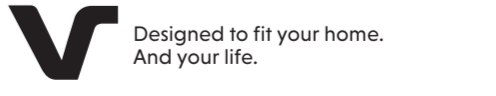

VTech Technologies Canada Ltd.
A member of THE VTECH GROUP OF COMPANIES.
VTech is a registered trademark of VTech Holdings Limited.
Specifications are subject to change without notice.
© 2018 VTech Technologies Canada Ltd.
All rights reserved. 10/18. SN7021-X_CA_CIB_V1.0
Document order number: 91-011573-010-100

